

FONTANA LIMA COMMERCIAL ELECTRONIC SENSOR AUTOMATIC TOUCHLESS COMMERCIAL SOAP DISPENSER SPECS

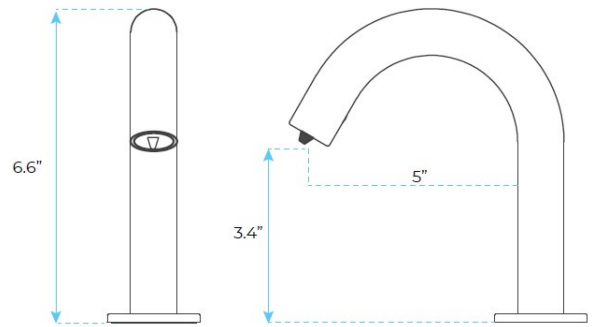

SPECS:

- Product Type: Commercial
- Main Construction Material: Brass
- Mount Type: Deck
- Handle Type: Infra-Red
- Power Rating: DC6V (4pcs alkaline batteries)
- Batteries Required: 4 AA Batteries (not supplied)
- Number of Tap Holes: 1
- Valve/Cartridge Type: Solenoid Valve
- Plumbing System Requirements: Suitable for all plumbing systems
- Sensing Range: 2.4-3.9 in (6-10 cm)
- Activation Time: 0.5 - 1 secs
- Soap capacity: 1500ML
- Isolation Included: No

